



VAI61..



VBI61..

ACVATIX™

2-port and 3-port ball valves PN40

VAI61..
VBI61..

with internally threaded connections

- Brass UNS C35330 (DZR) ball valve body
- DN 15...50
- k_{vs} 1...63 m³/h
- Internally threaded connections Rp as per ISO 7-1
- Angle of rotation 90°
- For use with rotary actuators GQD..9A, GMA..9E with spring-return and GDB..9E, GLB..9E without spring return
- Applications with auxiliary functions (e.g., switch, potentiometer, see p. 3) can also be combined with standard rotary actuators.

Use

For use in heating, ventilating and air conditioning plants as a control or safety shutoff valve.

For closed circuits (avoid cavitation, see page 5).

Type summary

Type		DN	k_{vs} [m ³ /h]	S_v
2-port	3-port			
VAI61.15-1	-	15	1.0	> 500
VAI61.15-1.6	VBI61.15-1.6		1.6	
VAI61.15-2.5	VBI61.15-2.5		2.5	
VAI61.15-4	VBI61.15-4		4.0	
VAI61.15-6.3	VBI61.15-6.3		6.3	
VAI61.15-10	-		10	
VAI61.20-4	VBI61.20-4	20	4	
VAI61.20-6.3	VBI61.20-6.3		6.3	
VAI61.20-10	-		10	
VAI61.25-6.3	-	25	6.3	
VAI61.25-10	VBI61.25-10		10	
VAI61.25-16	-		16	
VAI61.32-10	-		10	
VAI61.32-16	VBI61.32-16	32	16	
VAI61.32-25	-		25	
VAI61.40-16	-	40	16	
VAI61.40-25	VBI61.40-25		25	
VAI61.40-40	-		40	
VAI61.50-25	-	50	25	
VAI61.50-40	VBI61.50-40		40	
VAI61.50-63	VBI61.50-63		63	

DN = nominal size

k_{vs} = nominal flow rate of cold water (5...30 °C) through the fully open ball valve at a differential pressure of 100 kPa (1 bar)

S_v = rangeability k_{vs} / k_{vr}

k_{vr} = smallest k_v value at which the flow characteristic tolerances can still be maintained at a differential pressure of 100 kPa (1 bar)

Accessories

For thermal insulation, separate insulation covers are available.

Ball valve	Insulation cover
VAI61.15..	ALI15VAI60/61
VAI61.20..	ALI20VAI60/61
VAI61.25..	ALI25VAI60/61
VAI61.32..	ALI32VAI60/61
VAI61.40..	ALI40VAI60/61
VAI61.50..	ALI50VAI60/61

Ball valve	Insulation cover
VBI61.15..	ALI15VBI60/61
VBI61.20..	ALI20VBI61
VBI61.25..	ALI25VBI60/61
VBI61.32..	ALI32VBI60/61
VBI61.40..	ALI40VBI60/61
VBI61.50..	ALI50VBI60/61

Equipment combinations

Type	Rotary actuators							
	GQD..9A		GDB..9E		GMA..9E		GLB..9E	
	Δp_{max}	Δp_s	Δp_{max}	Δp_s	Δp_{max}	Δp_s	Δp_{max}	Δp_s
Ball valve	[kPa]							
VAI61.15..	350	1'400	350	1'400	350	1'400	350	1'400
VAI61.20..								
VAI61.25..								
VAI61.32-10	1'000	350	1'000					
VAI61.32-16								
VAI61.32-25								
VAI61.40-16	800	350	800					
VAI61.40-25								
VAI61.40-40								
VAI61.50-25	600	350	600					
VAI61.50-40								
VAI61.50-63								

VBI61.15..	350		350		350	350	
VBI61.20..							
VBI61.25-10							
VBI61.32-16					350	350	
VBI61.40-25							
VBI61.50-40							
VBI61.50-63							

Δp_{max} = maximum permissible differential pressure across ball valve's control path, valid for the entire actuating range of the motorized ball valve; for low noise operation, we recommend a maximum permissible differential pressure of 200 kPa

Δp_s = maximum permissible differential pressure at which the motorized ball valve will close securely against the pressure (close off pressure)

Rotary actuators for ball valves (overview)

Type / Stock no.	Actuator type	Operating voltage	Positioning		Spring return		Data Sheet
			signal	time	function	time	
GQD131.9A	Electro-motoric	AC/DC 24 V	3-position	30/15 s ¹⁾	Yes	15 s	N4659
GQD161.9A			DC 0...10 V				
GDB331.9E	Electro-motoric	AC 230 V	3-position	150 s			N4657
GDB131.9E		AC 24 V					
GDB161.9E			DC 0...10 V				
GMA131.9E	Electro-motoric	AC / DC 24 V	3- position	90/15 s ¹⁾	Yes	15 s	N4658
GMA161.9E			DC 0...10 V				
GLB331.9E	Electro-motoric	AC 230 V	3-position	150 s			N4657
GLB131.9E		AC 24 V					
GLB161.9E			DC 0...10 V				

¹⁾ open/close

Ordering

When ordering please give material, article type, purchase order text and quantity.
Example:

Material	Article Type	Purchase Order (PO) text	Quantity
VAI61.25-16	VAI61.25-16	Ball valve inside threaded, 2-Port	2
GLB161.9E	GLB161.9E	Actuator for Ball valve, NSR	2

Spare parts, Rev. no.

See overview, page 10.

Delivery

Ball valves, rotary actuators and mounting sets are supplied in separate packaging and not assembled prior to delivery.

Applications with auxiliary functions

If a ball valve application requires a rotary actuator with auxiliary functions (for example switch or potentiometer), a standard actuator with a corresponding function can be used. In this case, a mounting set ASK77.. is required **in addition** to the rotary actuator.

For assembly please consult mounting instructions accordingly.

Rotary actuators	Option	Mounting set (order text)
GMA..1E (with spring-return)	Potentiometer, switches	ASK77.2 Accessory Kit BV for GMAxx1.9E
GDB..1E / GLB..1E (without spring-return)	Potentiometer, switches	ASK77.3 Accessory Kit BV for GDBxx1.9E
GQD..1A (with spring-return)	Switches	ASK77.4 Accessory Kit for BV GQDxx1.9A

Note: GAP19../GNP19.. are not compatible with mounting set ASK77.2.

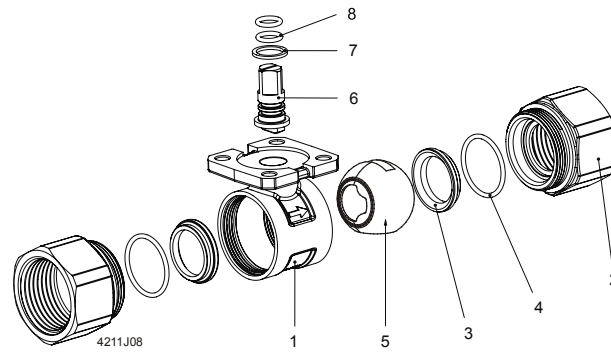

Parts

- 1 Body
- 2 Connection with internal thread
- 3 Seat
- 4 O-ring
- 5 Ball with integral characterized bore
- 6 Stem
- 7 Antifriction washer
- 8 O-ring

Sizing

Flow diagram

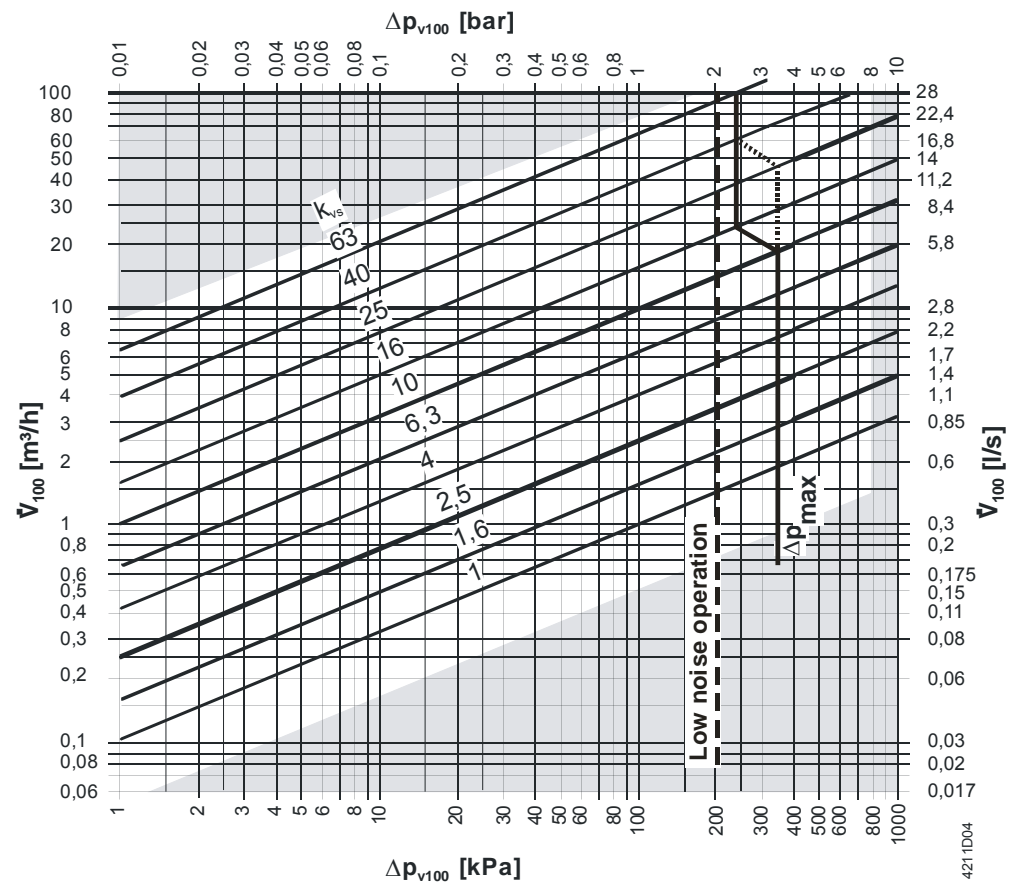

----- Δp_{max} for VAI61.. and VBI61.. see table equipment combinations for details

Δp_{max} = maximum permissible differential pressure across the ball valve, valid for the entire actuating range of the motorized ball valve; for low noise operation, we recommend a maximum permissible differential pressure of 200 kPa

Δp_{v100} = differential pressure across the fully open ball valve and the ball valve's control path at a volumetric flow V_{100}

V_{100} = volumetric flow through the fully open ball valve

100 kPa = 1 bar \approx 10 mWC

1 m³/h = 0.278 l/s water at 20 °C

Ball valve flow characteristic

2-port

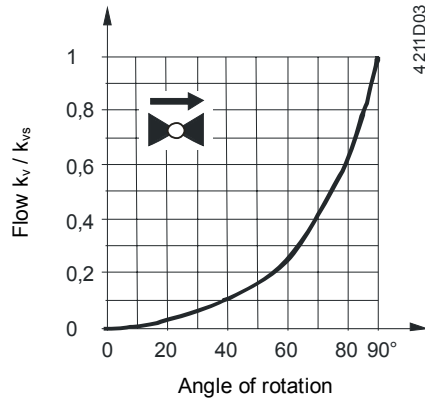

Flow characteristic

0...100 %: → A – AB equal-percentage, $n_{gl} = 3.9$ as per VDI / VDE 2173

3-port

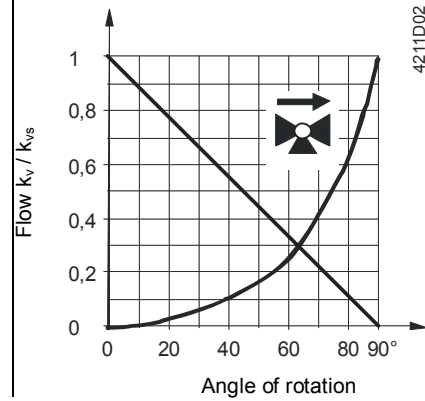

Through-port 0...100 %: → equal-percentage, $n_{gl} = 3.9$ as per VDI / VDE 2173

Bypass 0...100 %: → B – AB linear, $k_{vs} > 70\%$ of A – AB

Cavitation

Cavitation accelerates wear on the ball and seat, and also results in undesirable noise. Cavitation can be avoided by not exceeding the differential pressure shown in the flow diagram on page 4, and by adhering to the static pressures shown below.

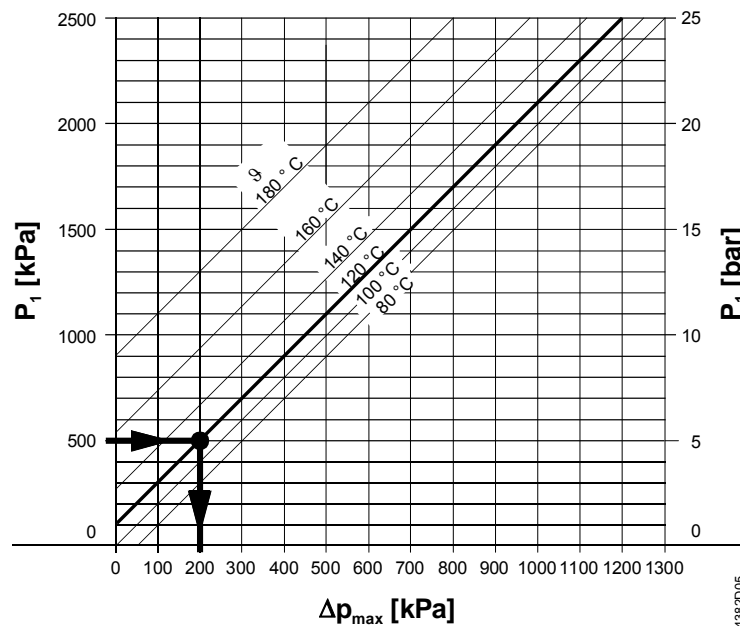

- Δp_{max} = differential pressure with ball valve almost closed at which cavitation can largely be avoided
- p_1 = static pressure at ball valve inlet
- p_3 = static pressure at ball valve outlet
- M = pump
- ϑ = water temperature

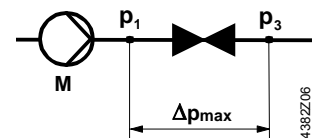

High temperature hot water example:

Pressure p_1 at ball valve inlet: 500 kPa (5 bar)
Water temperature: 120 °C

From the diagram above, it will be seen that with the ball valve almost closed, the maximum permissible differential pressure Δp_{max} is 200 kPa (2 bar).

Note on chilled water

To avoid cavitation in chilled water circuits, ensure sufficient counter-pressure at the ball valve's outlet, e.g. with an additional throttling ball valve downstream from

the ball valve. Select the maximum differential pressure across the ball valve according to the 80 °C curve in the flow diagram above.

Operating pressure and temperature
Fluids

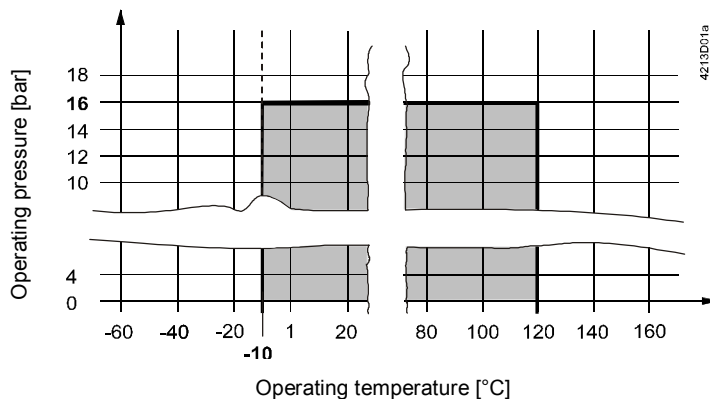

Operating pressure and medium temperature as per ISO 7005

Current local legislation must be observed.

Notes

Engineering

We recommend installation in the return pipe, as the temperatures in this pipe are lower for applications in heating systems, which extends the stem sealing gland's life.

Ensure cavitation-free flow (refer to page 5).

Always use a strainer upstream of the ball valve to increase the ball valve's functional safety.

Mounting

Ball valve and rotary actuator can easily be assembled on site. Neither special tools nor adjustments are required.

The ball valve is supplied with Mounting Instructions (VAI61.., VBI61..: 74 319 0647 0).

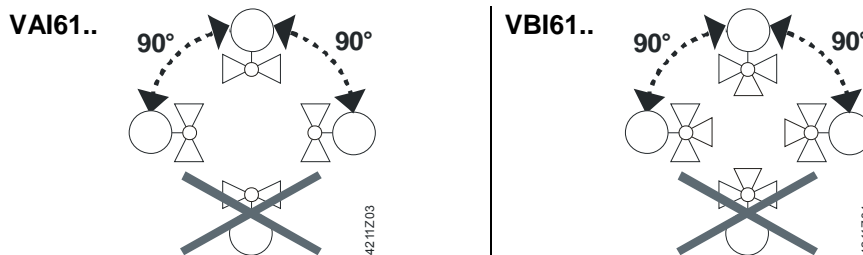

Orientation



Direction of flow

When mounting, pay attention to the ball valve's flow direction symbol.

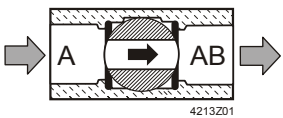

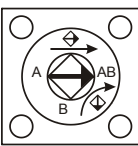
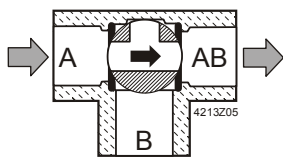
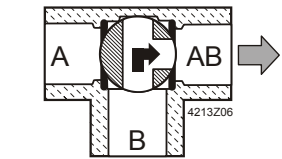
Ball valve	Laser mark	Delivery position	Turned 90 °
VAI61.. Control ball valve 2-port	-	 A - AB = 100 %	 A - AB = 0 %
VBI61.. Control ball valve 3-port		 A - AB = 100 % B - AB = 0 %	 A - AB = 0 % B - AB = 100 %

Pipe connection

Prevent leakage

- Manufacture screw fittings per ISO 7-1: Ball valves (internal threading) = "Rp"; piping (external threading) = "R".
- Do not use too much hemp or PTFE tape.
- Do not damage threading, e.g. by screwing on fitting "until it no longer turns".
- Apply pliers/wrench on the ball valve nut that is closer to the piping.

Commissioning

Commission the ball valve only if the rotary actuator has been mounted correctly.

Ball valve stem moves counterclockwise: Ball valve opens = increasing flow
 Ball valve stem moves clockwise: Ball valve closes = decreasing flow

Maintenance

VAI61.. and VBI61.. ball valves are maintenance-free.

Warning

When doing service work on the ball valve / rotary actuator:

- Deactivate the pump and turn off the power supply
- Close the shutoff ball valves
- Fully reduce the pressure in the piping system and allow pipes to completely cool down

If necessary, disconnect the electrical wires.

Before putting the ball valve into operation again, make sure the rotary actuator is correctly fitted.

Disposal



The valve is considered an electronics device for disposal in terms of European Directive 2012/19/EU and may not be disposed of as domestic garbage.

- Disassemble the valve into individual parts prior to disposing of it and sort the individual parts by the various types of materials.
- Comply with all local and currently applicable laws and regulations.

Warranty

The technical data given for applications is valid only in conjunction with the Siemens rotary actuators listed under "Equipment combinations", page 2.

All terms of the warranty will be invalidated if rotary actuators of other manufacture are used.

Technical data

	VAI61..	VBI61..	
Functional data	PN class	PN 40 as per ISO 7268	
	Operating pressure	To ISO 7005 within the permissible medium temperature range according to diagram on page 6	
	Ball valve characteristic		
	Through-port 0...100 %	equal-percentage; $n_{gl} = 3.9$ as per VDI / VDE 2173	equal-percentage; $n_{gl} = 3.9$ as per VDI / VDE 2173
	Bypass 0...100 %		linear
	Leakage rate		
	Through-port	„Waterproof“ as per EN 60534-4 L/1, better than class 5	„Waterproof“ as per EN 60534-4 L/1, better than class 4
	Bypass		< 1 %
	Permissible media	Cold water, chilled water, low temperature hot water, high temperature hot water, water with anti-freeze. Recommendation: water treatment to VDI 2035	
	Medium temperature	-10...120 °C	
Rangeability S_v	> 500		
Angle of rotation	90 °		
Materials	Ball valve body	Brass UNS C35330 (DZR)	
	Ball	Brass UNS C35330 (DZR), chromium-plated	
	Stem	Brass UNS C35330 (DZR)	
	Gland	EPDM O-rings	
Dimensions / weight	Refer to "Dimensions" below		
	Internally threaded connections	Rp as per ISO 7-1	
Standards	Pressure Equipment Directive	PED 2014/68/EU	
	Pressure accessories	Scope: Article 1, section 1 Definitions: Article 2, section 5	
	Fluid group 2	Without CE marking as per article 4, section 3 (sound engineering practice)	
	Environmental compatibility	The product environmental declaration CE1E4211de ¹⁾ contains data on environmentally compatible product design and assessments (RoHS compliance, materials composition, packaging, environmental benefit, disposal).	

¹⁾ The documents can be downloaded from <http://siemens.com/bt/download>.

Dimensions

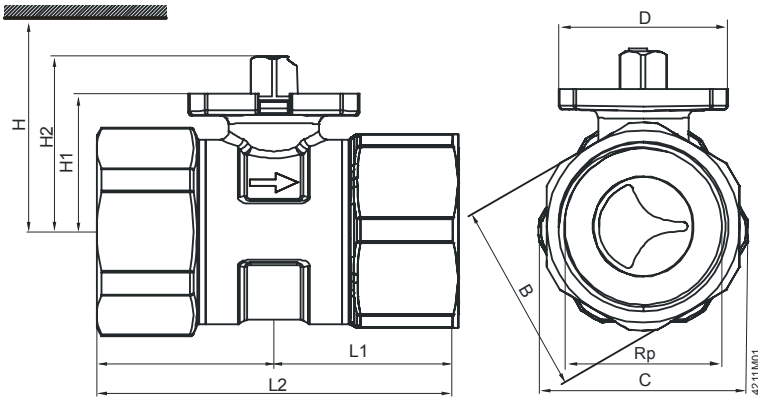

- DN = Nominal size
 H = Total actuator height plus minimum distance to the wall or the ceiling for mounting, connection, operation, service, etc.
 H1 = Dimension from the pipe centre to install the actuator (upper edge)

Type	DN	B [mm]	C [mm]	D [mm]	Rp [Inch]	L1 [mm]	L2 [mm]	H1 [mm]	H2 [mm]	H				[kg]
										GQD..9A [mm]	GDB..9E [mm]	GMA..9E [mm]	GLB..9E [mm]	
VAI61.15..	15	26	31 ¹⁾	42	Rp ½	31	62	27.6	37.6	> 300	> 300	> 300	> 300	0.3
VAI61.20..	20	31	34	42	Rp ¾	33	68	27.6	37.6					0.35
VAI61.25..	25	39	42.5	42	Rp 1	38.5	77	30.5	40.5	> 320	> 320	> 320	> 320	0.5
VAI61.32..	32	48	52	42	Rp 1¼	44	88	34.3	44.3					0.7
VAI61.40..	40	55	61	42	Rp 1½	48.5	102	39.8	49.8					1.1
VAI61.50..	50	67	74	42	Rp 2	58.1	116.2	52.8	62.8			> 335	> 335	1.8

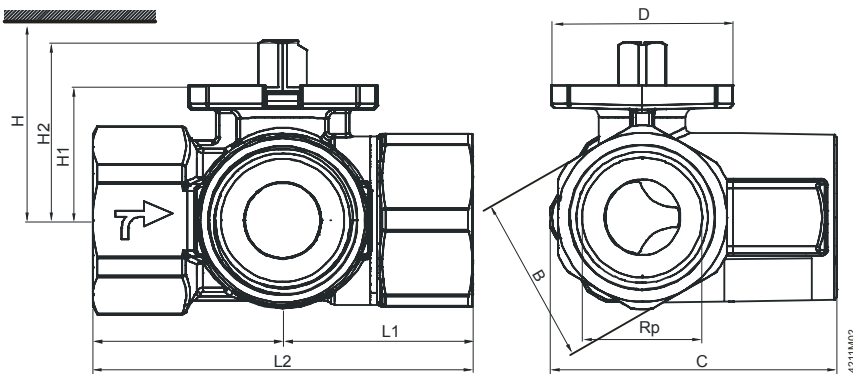

- DN = Nominal size
 H = Total actuator height plus minimum distance to the wall or the ceiling for mounting, connection, operation, service, etc.
 H1 = Dimension from the pipe centre to install the actuator (upper edge)

Type	DN	B [mm]	C [mm]	D [mm]	Rp [Inch]	L1 [mm]	L2 [mm]	H1 [mm]	H2 [mm]	H				[kg]
										GQD..9A [mm]	GDB..9E [mm]	GMA..9E [mm]	GLB..9E [mm]	
VBI61.15..	15	26	48.5 ¹⁾	42	Rp ½	33.5	67	24.2	33.7	> 300	> 300	> 300	> 300	0.29
VBI61.15-6.3			49.5 ¹⁾	42				27.6	37.6					0.305
VBI61.20..	20	31	52	42	Rp ¾	36	72	27.6	37.6	> 320	> 320	> 320	> 320	0.375
VBI61.25..	25	39	64.5	42	Rp 1	42.5	85	30.5	40.5					0.605
VBI61.32..	32	48	76.5	42	Rp 1¼	49.5	99	34.3	44.3			> 320	> 320	0.95
VBI61.40..	40	55	84.5	42	Rp 1½	55	110	39.8	49.8					1.365
VBI61.50..	50	67	102.5	42	Rp 2	65.5	131	52.8	62.8			> 335	> 335	2.215

¹⁾ Body larger than union nut

Dimensions with insulation covers
for ball valves 2-port (VAI61..)

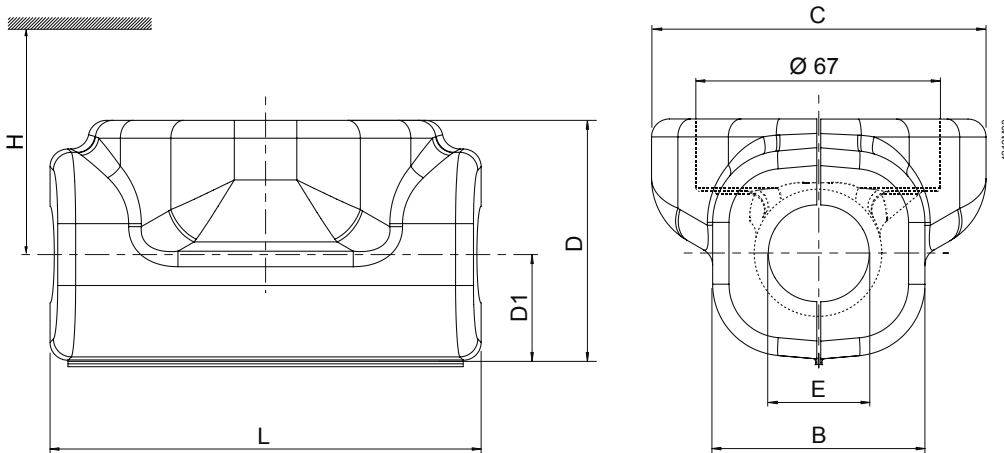

DN = Nominal size
H = Total actuator height plus minimum distance to the wall or the ceiling for mounting, connection, operation, service, etc.

Type		DN	B [mm]	C [mm]	D [mm]	D1 [mm]	E [mm]	L [mm]	H				kg [g]
Insulation cover	to ball valve								GQD..9A [mm]	GDB..9E [mm]	GMA..9E [mm]	GLB..9E [mm]	
AL15VAI60/61	VAI61.15..	15	56	95	65	27	21	100	> 300	> 300	> 300	> 300	15
AL20VAI60/61	VAI61.20..	20	56	95	66	32	27	105					16
AL25VAI60/61	VAI61.25..	25	56	95	80	37	34	108	> 320	> 320	> 320	> 320	20
AL32VAI60/61	VAI61.32..	32	86	100	95	47	43	130					28
AL40VAI60/61	VAI61.40..	40	95	102	98	50	48	140					32
AL150VAI60/61	VAI61.50..	50	105	96	110	56	61	160			> 335	> 335	36

Dimensions with insulation covers
for ball valves 3-port (VBI61..)

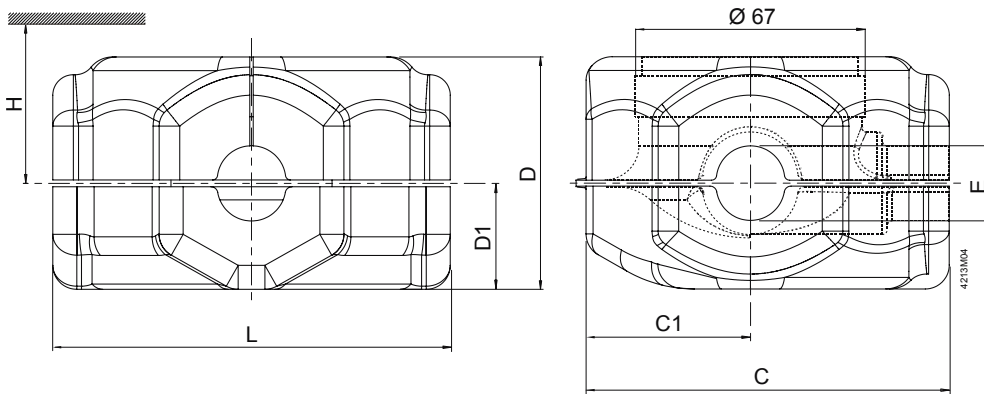

DN = Nominal size
H = Total actuator height plus minimum distance to the wall or the ceiling for mounting, connection, operation, service, etc.

Type		DN	C [mm]	C1 [mm]	D [mm]	D1 [mm]	E [mm]	L [mm]	H				kg [g]
Insulation cover	to ball valve								GQD..9A [mm]	GDB..9E [mm]	GMA..9E [mm]	GLB..9E [mm]	
AL15VBI60/61	VBI61.15..	15	100	50	70	34	21	100	> 300	> 300	> 300	> 300	21
AL20VBI61	VBI61.20..	20	115	55	80	40	27	120					30
AL25VBI60/61	VBI61.25..	25	115	55	80	40	34	120	> 320	> 320	> 320	> 320	30
AL32VBI60/61	VBI61.32..	32	125	55	95	45	43	150					41
AL40VBI60/61	VBI61.40..	40	125	55	95	45	48	150					43
AL150VBI60/61	VBI61.50..	50	145	60	110	54	61	170			> 335	> 335	51

Revision numbers

Product number	Valid from rev. no.	Product number	Valid from rev. no.
VAI61.15-1	..A		
VAI61.15-1.6	..A	VBI61.15-1.6	..A
VAI61.15-2.5	..A	VBI61.15-2.5	..A
VAI61.15-4	..A	VBI61.15-4	..A
VAI61.15-6.3	..A	VBI61.15-6.3	..A
VAI61.15-10	..A		
VAI61.20-4	..A	VBI61.20-4	..A
VAI61.20-6.3	..A	VBI61.20-6.3	..A
VAI61.20-10	..A	VBI61.20-10	..A
VAI61.25-6.3	..A		
VAI61.25-10	..A	VBI61.25-10	..A
VAI61.25-16	..A		
VAI61.32-10	..A		
VAI61.32-16	..A	VBI61.32-16	..A
VAI61.32-25	..A		
VAI61.40-16	..A		
VAI61.40-25	..A	VBI61.40-25	..A
VAI61.40-40	..A		
VAI61.50-25	..A		
VAI61.50-40	..A	VBI61.50-40	..A
VAI61.50-63	..A	VBI61.50-63	..A

Issued by
Siemens Switzerland Ltd
Building Technologies Division
International Headquarters
Gubelstrasse 22
6301 Zug
Switzerland
Tel. +41 41-724 24 24
www.siemens.com/buildingtechnologies

© Siemens Switzerland Ltd, 2010
Technical specifications and availability subject to change without notice.